

Design for Assembly

DFA with Suppliers

Supplier DFA Objective

- Leverage supplier domain expertise
- Eliminate design modifications required for schedule, cost and/or producibility
- Achieve the required function with a minimum of
 - parts
 - labor
 - opportunities for mistakes
- Improve robustness, quality and value

Cost, Quality & Cycle Time

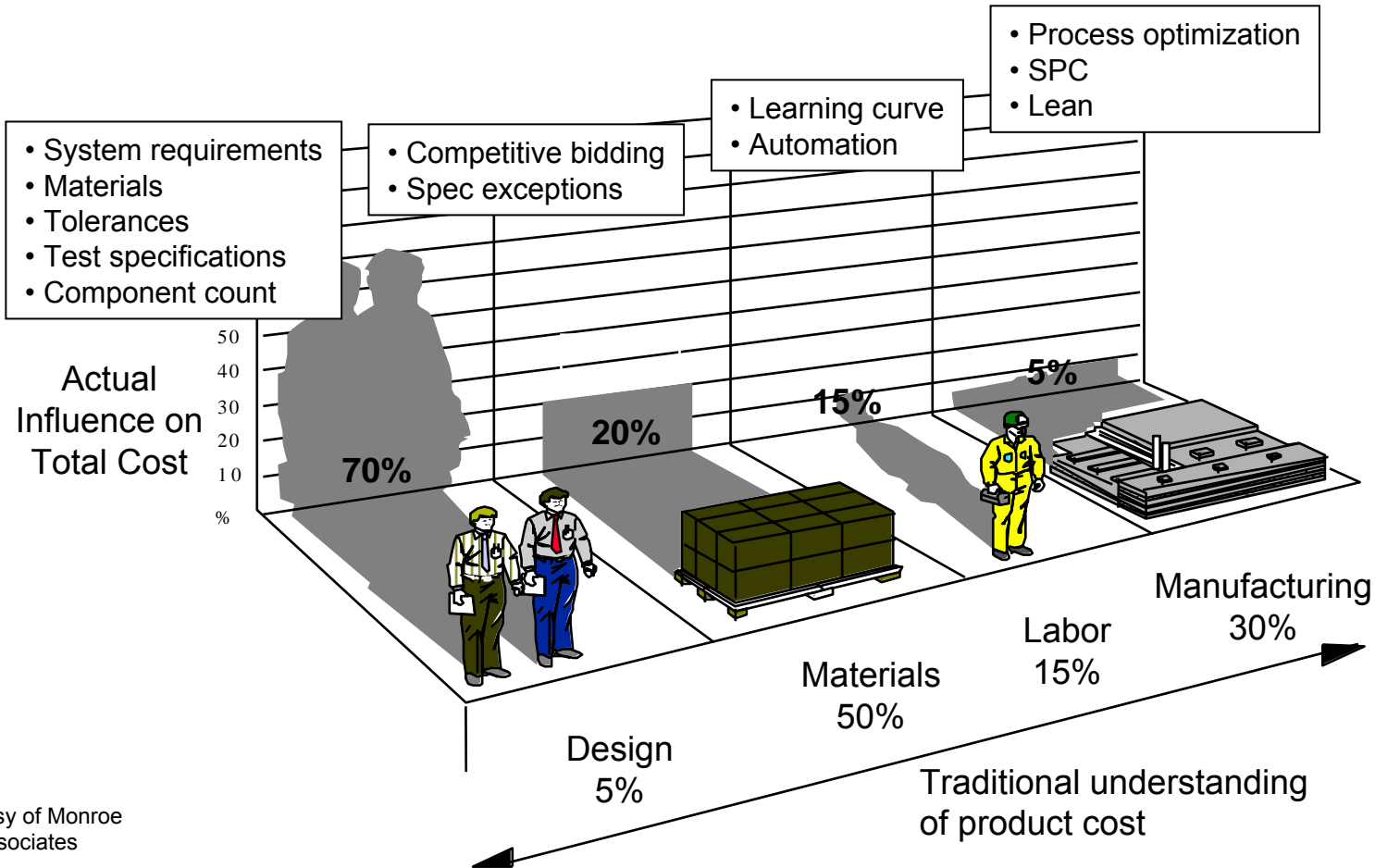

Courtesy of Monroe and Associates

The design phase provides the best opportunity to reduce total cost

Maximizing Customer Value Through DFA

- We have a shared responsibility to provide the best value to our customers
- Optimum design satisfies customer requirements and manufacturing capabilities at minimum complexity and cost
- DFA connects the designers responsible for achieving the functional customer requirements of the design to the manufacturing and supplier teams responsible for successful execution

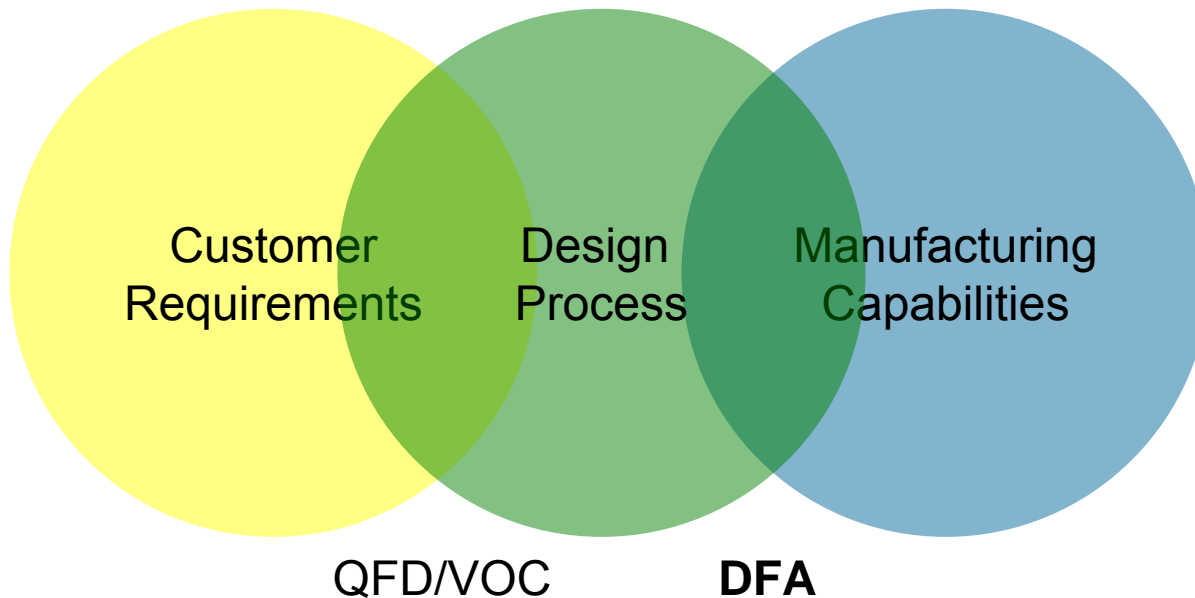

The Yield Impact from Reducing Complexity

Reduced Complexity

# of parts/steps	Sigma Level Impact on First Pass Yield			
	$\pm 3\sigma$	$\pm 4\sigma$	$\pm 5\sigma$	$\pm 6\sigma$
1	93.3%	99.4%	99.98%	99.999966%
10	50.1%	94.0%	99.77%	99.9966%
30	12.6%	83.0%	99.30%	99.99%
50	---	73.2%	98.84%	99.98%
100	---	53.6%	97.70%	99.97%
150	---	39.4%	96.61%	99.95%
200	---	28.8%	95.45%	99.93%
219	---	25.6%	95.03%	99.92%
250	---	21.1%	94.35%	99.91%
300	---	15.4%	93.26%	99.90%
349	---	11.4%	92.20%	99.88%
350	---	11.3%	92.18%	99.86%

DFM

DFA

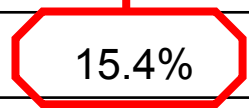
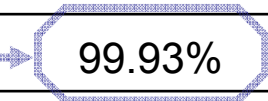

The Help We Need From Our Suppliers

- Provide a DFA review of the design and identify opportunities to reduce assembly complexity, cost and producibility risk
 - Designers have system performance expertise—how the design affects performance
 - Suppliers have assembly, process and test expertise—how the design affects producibility and drives cost
- System performance expertise and assembly process and test expertise are both necessary to optimize any design for producibility, cost and performance

Suppliers can help designers understand how requirements drive product cost, schedule and quality risk—and where improvement opportunities exist

Textbook Example of DFA

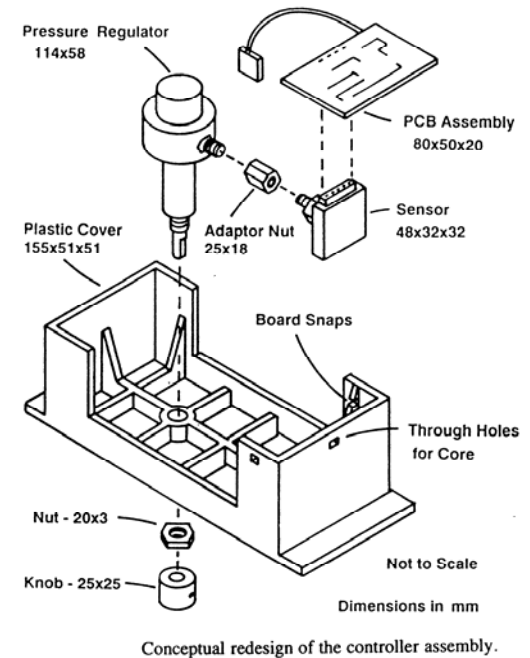
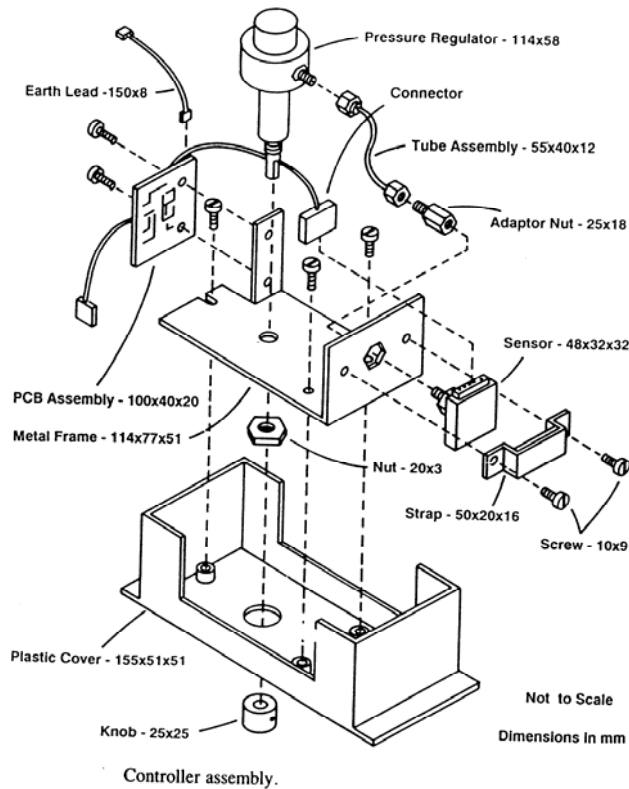

The DFA objective is to achieve the required function with a minimum of parts, labor and opportunities for mistakes

Source: 1. [Product Design for Manufacture & Assembly](#): Boothroyd, Dewhurst & Knight

DFA Principles¹

1. Minimize the number of parts
2. Minimize the use of fasteners
3. Standardize
4. Avoid difficult components
5. Use modular subassemblies
6. Use multifunctional parts
7. Minimize reorientation's
8. Use self-locating features
9. Avoid ST/STE
10. Provide accessibility
11. Minimize process steps

DFA Guidelines²

1. Overall component count should be minimized
2. Make minimize use of separate fasteners
3. Design a base component for locating other components
4. Do not require the base to be repositioned during assy
5. Make the assembly sequence efficient
6. Avoid characteristics that complicate removal
7. Design components for a specific type of retrieval, handling & insertion
8. Design for end-to-end symmetry
9. Design for symmetry about their axes of insertion
10. Design components that are not symmetric about their axes of insertion to be clearly asymmetric
11. Design components to mate through straight line assembly, all from the same direction
12. Make use of chamfers, leads, and compliance to facilitate insertion & alignment
13. Maximize component accessibility

Sources: 1. [Product Design for Manufacture & Assembly](#): Boothroyd, Dewhurst & Knight
2. [The Mechanical Design Process](#): Ullman & Ullman

1. Minimize Mechanical Part Count

- ESSENTIAL PART or NOT?
- If the item's function is **ONLY** to fasten, secure, or connect other items then the item is **NON-ESSENTIAL**
 - Does it have to move?
 - Does it have to be a different material?
 - Is it required for assembly or disassembly?
- Relative to all parts already assembled
- If the answer is "NO" to all 3 questions, then the part is a candidate for elimination or combination with other parts.

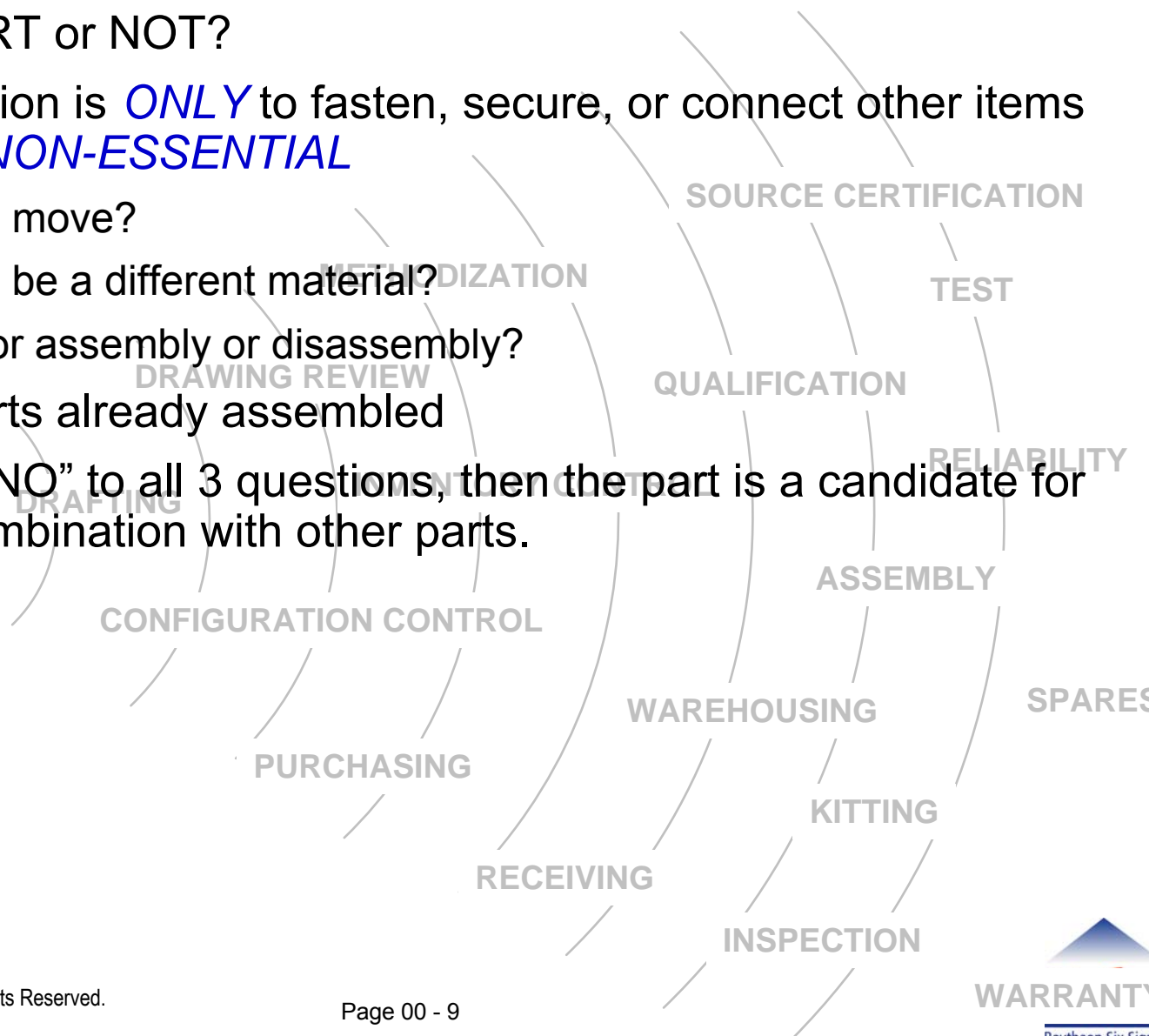
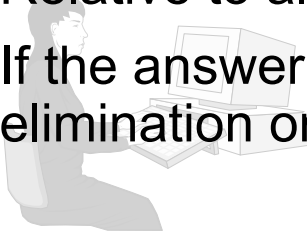

2. Minimize Use of Fasteners

- Most frequently disregarded principle
- Most costly operation in assembly
- Fasteners reduce automation opportunities
- Fasteners require work station support
- Fasteners contribute to Carpal Tunnel Syndrome
- Most frequent cause of product failures

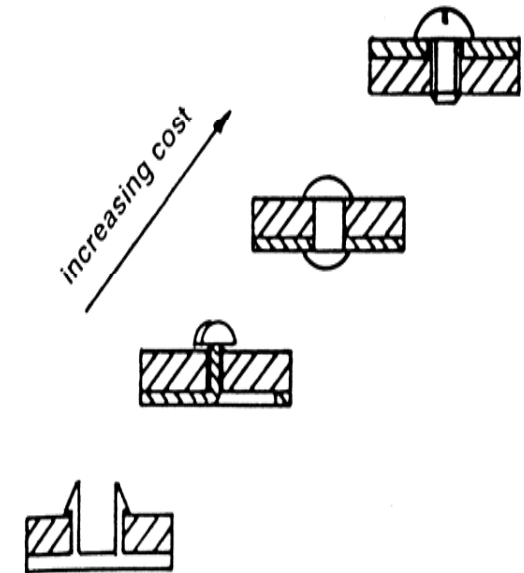

- If screws have to be used:

- Flanged head
- Internal Allen Drive with shank Length to Head diameter ratio 1.5 min

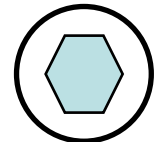
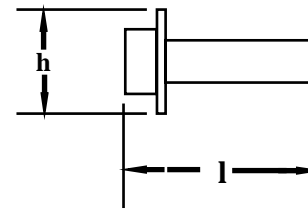
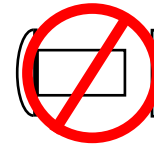
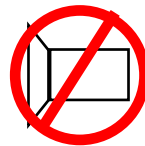
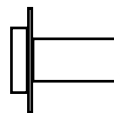

Source: 1. [Product Design for Manufacture & Assembly](#): Boothroyd, Dewhurst & Knight

3. Standardize

- Simplifies engineering design & assembly documentation efforts
- Reduces procurement, inspection, & inventory costs
- Facilitates automation
- Eliminates defects caused by confusion
- Promotes design reuse
- Standardize components, subassemblies, materials, processes, part orientations
- Use industry standard parts; minimize use of custom components
 - Minimizes obsolescence
 - >65% industrial or commercially available components

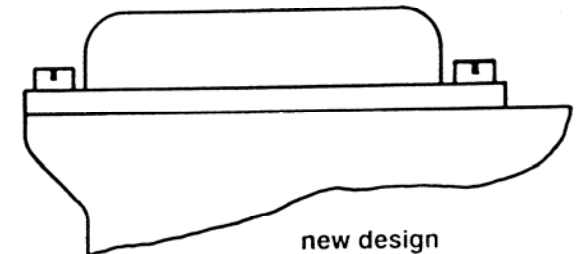
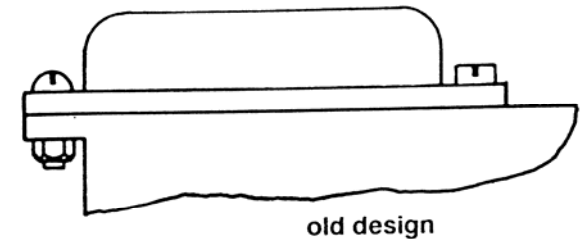

Standardize parts.

Source: 1. [Product Design for Manufacture & Assembly](#): Boothroyd, Dewhurst & Knight

4. Avoid Difficult Components

- What is a Difficult Component?
 - Components that cause difficulty during assembly and result in increased handling and/or insertion time
 - Components that require more than one hand to grasp
 - Components that are delicate, heavy, flexible, sticky, tangle, nest, or are sharp, abrasive or slippery
 - Components whose orientation is difficult to see

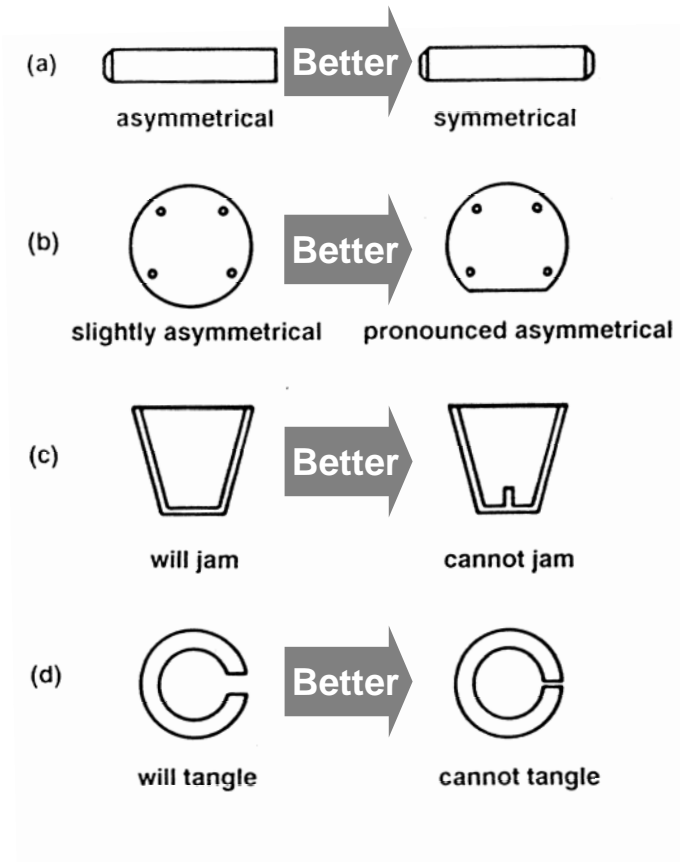

Source: 1. [Product Design for Manufacture & Assembly](#): Boothroyd, Dewhurst & Knight

5. Use Modular Subassemblies

- Modular subassemblies are standalone assemblies that can be assembled, inspected, and tested independently.
 - Reduced complexity at final assembly
 - Accomplishes functions common to many products in common subassemblies
 - Improves disassembly & repair
 - Reduces customer down time
 - Plug & play
 - Facilitates design reuse
 - Allows for future upgrade of current design
 - Improves testability
 - Allows break-points for outsource
 - Improves quality & reliability

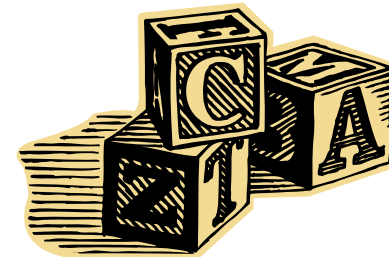

6. Design Multifunctional Parts

- Multifunctional parts can be used in more than one place for the same or multiple functions
 - Reduces development & production cycle time
 - Reduces assembly defects
 - Minimizes assembly tooling
 - Increase production volume of parts
 - Reduces inventory support activities
 - Combine function of several parts into one part
 - Make left-hand & right hand parts identical
 - Design parts that can be used in multiple places
 - Leverage the principle of symmetry when possible



7. Minimize Reorientations

- Facilitate automation
- Assemble in “Z” Axis motion
- Use gravity as an assembly process advantage
- Eliminate holding parts in place for subsequent assembly
- Avoid multiple turns, flipping or handling
- Reduce injuries (bending, stooping, reaching, tugging)



Eliminate...Minimize...Standardize...Productionize

8. Use Self Locating Features

- Self locating features provide a positive indication that the component, module, or subassembly has been assembled correctly without inspection or manipulation
 - chamfers
 - staggered leads
 - conforming features
 - lips
 - shoulders
 - tapers
 - tab in slot
 - keys
 - dog point screws

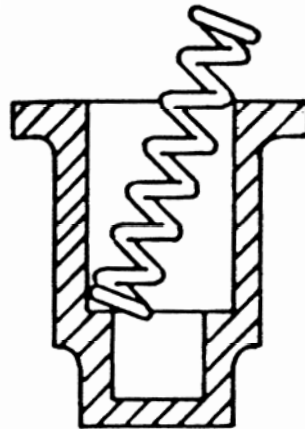

part can hang-up

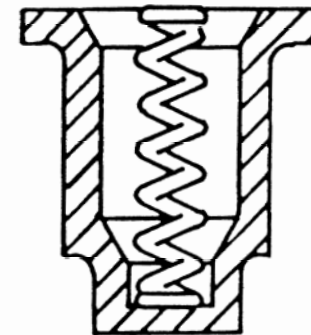

part falls into place

Provision of chamfers to allow easy insertion.

9. Avoid Special Tooling & Test Equipment

- When possible, avoid:
 - Non-standard hand tools
 - Complex fixtures
 - Special assembly & test equipment
 - Features requiring custom tooling for fabrication

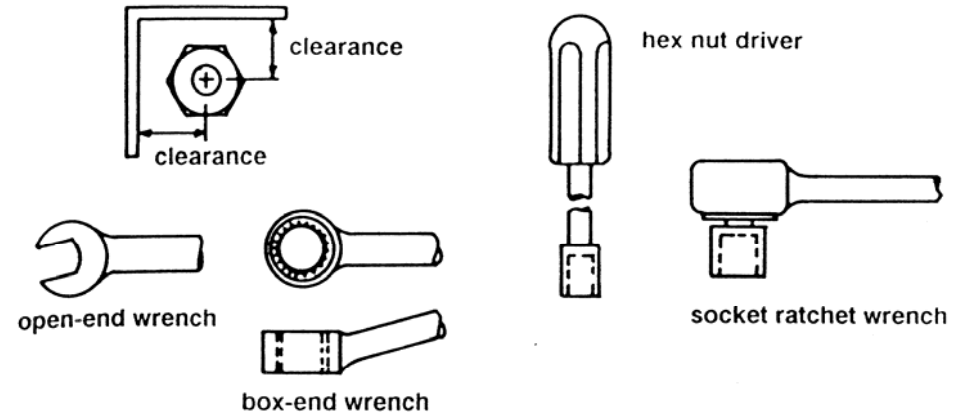

- Use hand operated fasteners for access to maintenance items

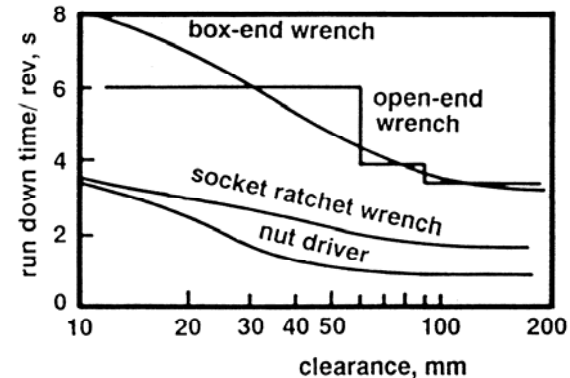

Source: 1. [Product Design for Manufacture & Assembly](#): Boothroyd, Dewhurst & Knight

10. Maximize Accessibility

- At assembly
 - Allow space around parts/components for tools
 - No stacked components or modules
- At test
 - Bring test points to outside of modules
- In the field
 - Periodic maintenance items – Last In, First Out (LIFO)
 - Maintenance without removal
- Also consider:
 - Customer's safety apparel
 - Maintenance routines
 - Testing and mounting requirements
 - Connectors
 - Captive fasteners
 - Human factors (ergonomics)

Restricted access for assembly of screws

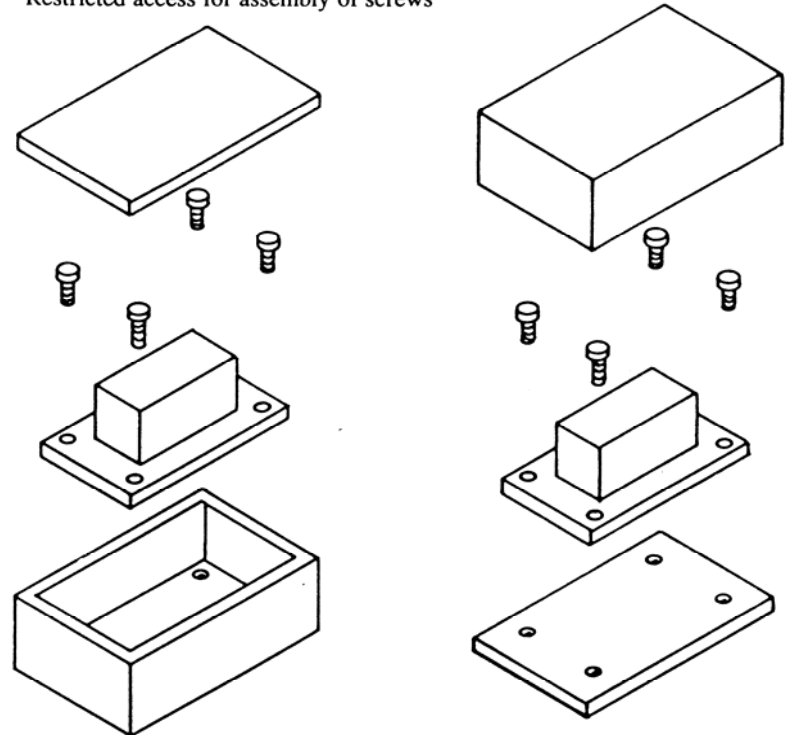

Design concept to provide easier access during assembly.

Source: 1. [Product Design for Manufacture & Assembly](#): Boothroyd, Dewhurst & Knight

11. Minimize Operations & Process Steps

- Each operation adds to product cost and schedule
- Design to use in “as is” or “as finished” condition
- Reduce/eliminate chemical treatment requirements
- Reduce plating/surface coating requirements
- Design for “No-Clean” operations
- Avoid dissimilar materials
- Minimize:
 - Fastening
 - Etching/plating
 - Joining/bonding
 - Hand soldering
 - Cleaning
 - Surface coatings
 - Finishing
 - Deburr/touch-up

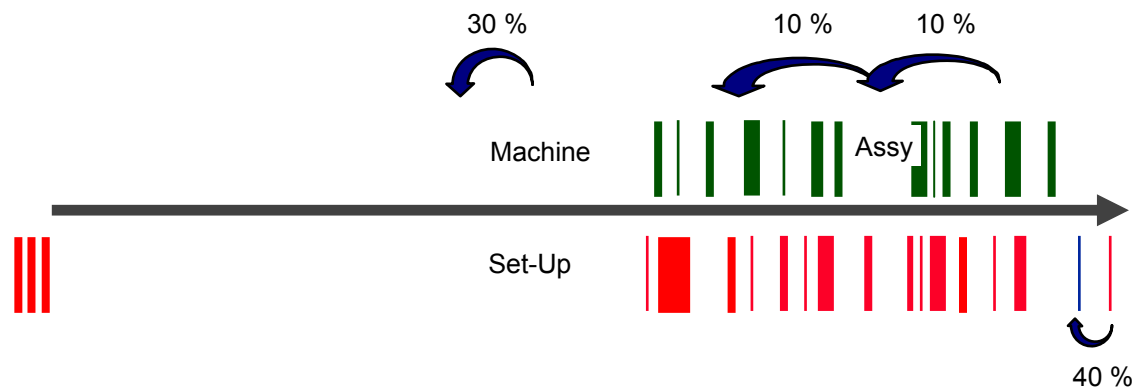
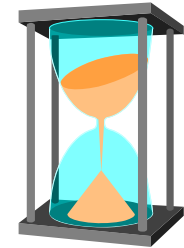

DFA Review Content

- Communicate knowledge of your assembly process capabilities where there is conflict between capability and requirement
- Highlight manufacturability concerns and propose alternatives if possible, for example:
 - Complexity
 - Unique or special processes
 - Difficult to use/procure materials or components
 - Difficult to measure/use datums
 - Lack of commonality
 - Lack of standardized parts

DFA Example

Objective: Design for Assembly Review
 Share knowledge of supplier process capabilities to optimize the design for assembly, producibility, cost and performance.
 Identification by suppliers of cost drivers and proposals for reduction or elimination based on supplier expertise



Drawing/Spec Number:	H000000-1
System/Subsystem:	PDU
Component:	Electromechanical Enclosure
Supplier Reviewer Name/Position:	Supplier Manufacturing Engineer, Supplier Applications Engineer
Raytheon Design Lead:	Raytheon Design Engineer

Item	Specification Section, Drawing Location	Description	Supplier Feedback		Supporting Information/Impact
			Supplier Concern	Supplier Recommendation	
1	A4, Sheet 1	Assembled unit	Multiple plates for enclosing each side adds parts and touch labor	Reduce and combine cover plates - use as formed piece	Reduces screw count in assembly 30 to 40%, reduces number of panels
2	C5, Sheet 3	Bracket	Mounting bracket to yoke adds parts and touch labor	Integrate brackets into machining of yoke	Reduces part count by 60 brackets and 120 screws, eases assemble less holding of parts
3	D2, Sheet 3	Cable divider	Cable divider to yoke adds parts and touch labor	Integrate cable divider support into yoke	Reduces screw count by 36
4	Sheet 1	Multiple screw types	Five different screws in assy	Consolidate to two flanged versions hex head; modify counterbore to maintain flush condition	Reduce PNs to procure and manage
5	Sheet 1	Assembled unit	Significant touch labor to install all fasteners--and unit to be disassembled upon receipt by customer for cabling	Assemble with enough fasteners to ship intact (~30% is sufficient)	Customer to assemble with all fasteners after cabling
6					
7					
8					
9					
10					
11					
12					
13					
14					
15					
16					
17					
18					
19					
20					
21					
22					
23					
24					
25					

Use the template to highlight to designers the cost-drivers caused by assembly requirements, special processes, etc.; propose your ideas on how to reduce cost, touch time, etc



Call to Action

- Provide a DFA review of the design to identify opportunities that reduce assembly complexity, cost and producibility risk
 - Designers have system performance expertise—how the design affects performance
 - Suppliers have assembly, process and test expertise—how the design affects producibility and drives cost
- Share your assembly process and test expertise with our designers to optimize designs for producibility, cost and performance

Suppliers can help designers understand how their requirements drive product cost, schedule and quality risk—and where improvement opportunities exist

References and Resources

Textbooks:

- [Product Design for Manufacture & Assembly](#): Boothroyd, Dewhurst & Knight
- [The Mechanical Design Process](#): Ullman & Ullman

On the Web:

- www.dfma.com

End

Raytheon

Customer Success Is Our Mission
