

Cobra Unmanned Aircraft System



Cobra UAS is a low-cost, highly reliable platform that supports small UAS systems development, integration and test. Cobra UAS received Experimental Airworthiness Certification from the Federal Aviation Administration Sept. 29, 2006.

Benefits

- Large payload volume and weight capacity
- Modular design for easy payload integration
- Extremely stable and predictable flight characteristics
- Onboard generator and power distribution unit
- Shielding to prevent electromagnetic interference
- Autonomous global positioning system (GPS) guidance
- Affordable system acquisition and operation

Description

Raytheon has designed, developed and is conducting flight operations with the Cobra Unmanned Aircraft System (UAS). Cobra UAS is designed as a test bed for the development, test and demonstration of sensor systems; networked command control and communications systems; UAS architectural concepts; and small weapons. Cobra UAS has proven to be an extremely cost-effective, reliable and maintainable system.

Cobra Air Vehicle

The Cobra UAS all-composite air vehicle combines a high-performance wing with a lifting body fuselage for a high payload to overall vehicle weight ratio. It has a wingspan of 10.2 feet, an overall length of 9.3 feet and maximum gross takeoff weight of more than 100 pounds. Of this, more than 45 pounds are allocated for fuel and payload; therefore, endurance is dependent on payload weight. For example, with a 25-pound payload, Cobra UAS has an endurance of longer than 3 hours.

Cobra UAS is equipped with a Desert Aircraft DA-150 engine, an air-cooled, two-cycle, two-cylinder power plant that produces 16.5 horsepower. A 500-watt generator provides primary electrical power and lithium polymer rechargeable batteries provide backup power.

Cloud Cap Technology's Piccolo II autopilot is used for guidance and navigation. Piccolo II provides the Cobra an advanced integrated avionics system specifically designed for small unmanned aircraft. The Piccolo avionics system includes the autopilot, flight sensors, navigation capability, global positioning system (GPS) receiver, wireless communication, payload interfaces, and command and control (C2) data link.

One standard Cobra UAS test configuration includes a mission computer, MicroLight™ data link radio and fixed electro-optical camera.

The onboard mission computer can process payload data and

format data for transmission to a ground or airborne control center or communications node. The 1.4 GHz Pentium® mission computer has an 8 GB solid-state hard drive for data storage.

Communication Links

The Raytheon MicroLight data link radio is the Cobra UAS's primary communication link for C2 and data transmission. The MicroLight is a miniature, software-defined radio that transports voice, video and data across a UHF network and supports multi-vehicle, networked C2.

- Frequency of 420–450 MHz
- Data rate of up to 1 Mbps
- Output power of 5 watts
- Range dependent on selected waveform and operating mode
- Secure but unclassified (SBU) security with Type 1 certification pending
- Ad hoc routing and automatic relay for range extension

The MHX-910 Microhard radio is an integral part of the Piccolo avionics system. It is

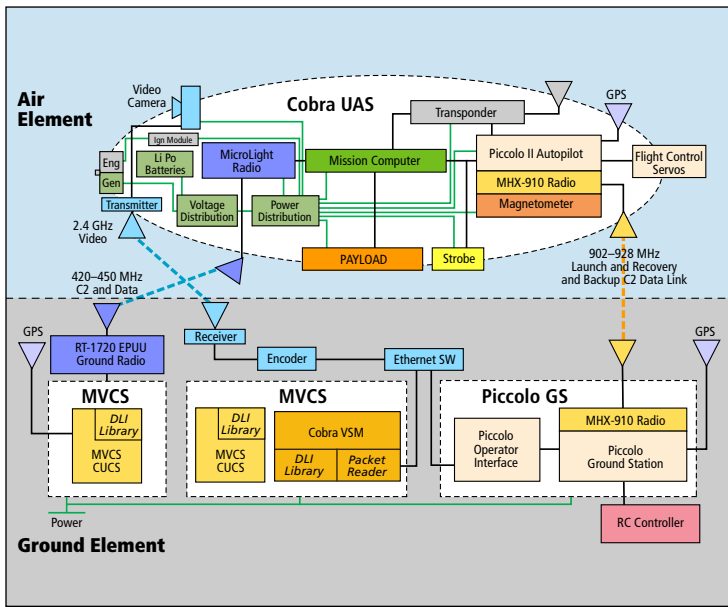

Cobra UAS block diagram



MicroLight™ radio

used during launch and recovery and as a backup C2 link.

- Frequency of 902–928 MHz
- Output power of 1 watt
- Range of approximately 20 nautical miles

The Cobra UAS also uses a commercial 2.4 GHz analog link for video transmission from the onboard, fixed camera to the ground.

Cobra Ground Element

The Cobra UAS ground element consists of two separate control systems: the Raytheon Multi-Vehicle Control System (MVCS) and the Cloud Cap

Technology Piccolo ground control station. The two control systems provide maximum flexibility and safety during payload testing.

The MVCS is network enabled allowing multiple pilot consoles to be connected to share data. The MVCS uses the STANAG 4586 interface to communicate with a UAS through a vehicle specific module (VSM) and accommodates complex mission plans. The MVCS supports electro-optical/infrared full motion streaming video and other advanced payloads.

The VSM is the interface or translator between the aircraft and the ground control station. It can reside in an airborne processor, as on the Cobra UAS, or at the ground control station. The Cobra VSM was created to communicate with the Piccolo autopilot and can be readily adapted to any UAS that uses a Piccolo autopilot.

Cobra UAS Specifications

Wingspan:	10.2 ft
Length:	9.3 ft
Maximum Gross Takeoff Weight:	>100 lbs
Payload:	Volume: 1.5 ft ³
	Weight Including Fuel: >45 lbs
Endurance with 20 lbs Fuel and 25 lbs Payload:	>3 hours
Air Speed:	Cruise: 50–60 kts
	Dash: 80 kts
Engine:	16.5 hp
Onboard Power:	Generator: 500 W
	Batteries: Lithium polymer
Guidance and Navigation:	Piccolo II and Piccolo Plus
C2:	System A: MVCS
	System B: Piccolo Ground Station
Communication Links:	
	C2 and Data: 420–450 MHz MicroLight
	C2: 902–928 MHz Microhard
	Analog Video: 2.4 GHz

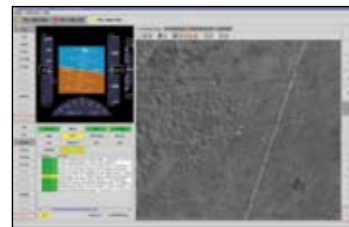

The Core UAS Control System (CUCS) provides the operator interface to the system controls and displays system and flight information to the pilot. The displays are configurable and include the primary flight display, a moving map or situational awareness display, warnings and cautions, and various data displays from the aircraft telemetry. This system can use satellite imagery for the moving map display. When more than one UAS telemetry stream is detected on the network, all UAS positions are shown on the map with an identification and altitude tag.

Summary

The Cobra UAS provides users with a low-cost, reliable test platform, advanced C2, and networked communications capability to support their UAS test needs. Raytheon is ready to support customer test needs with the Cobra UAS. Purchase, lease, training and test support are available.

The Cobra UAS received Experimental Airworthiness Certification from the Federal Aviation Administration Sept. 29, 2006.

Raytheon Company
Missile Systems
 Advanced Programs
 P.O. Box 11337
 Tucson, Arizona
 85734-1337 USA
 520.545.9761 phone
 520.545.9300 fax

www.raytheon.com



Customer Success Is Our Mission